



Durchflussmesser-Manufaktur



GH2 Source (RHM04)

**For Stationary Hydrogen Trailer
Filling Stations**

Datasheet

2026-03-17 EN V02

GH2 Source – Stationary Certified Custody Transfer Flow Measuring System for Gaseous Hydrogen

Safe filling of hydrogen trailers directly at the source

The GH2 Source volumetric measurement system is a reliable solution for calibratable stationary flow measurement when filling hydrogen trailers. The robust system was specially developed for use at hydrogen sources and downstream of compressors. Thanks to its combination of precise measurement technology and simple operation, GH2 Source is ideal as a basis for hydrogen billing in compliance with calibration regulations.

Flexible control to meet your requirements

GH2 Source provides high operation flexibility: filling can be started either via a customer-provided control signal for automated operation or manually for full control of the filling process. The system adapts perfectly to your operational workflows and safety requirements.

Robust design for demanding environments

Designed for continuous operation under extreme conditions, GH2 Source reliably handles high pressure levels and challenging industrial environments. The compact design allows for easy integration into existing systems – with or without a weatherproof equipment cabinet for optimal protection.

On-site verification service – minimal downtime

The legally required recalibration takes place every two years. It is preferably carried out conveniently on site by our mobile service teams using the RMS reference measurement system developed by Trigas. This minimizes downtime and maximizes the availability of your system. Alternatively, you can send your equipment to our ISO17025-certified calibration laboratory at TrigasFI. In both cases, we take care of organizing the calibration and all communication with the authorities.

Your benefits at a glance

- Traceable flow measurement as a legal basis for calculating hydrogen deliveries
- Flexible control via switching signal or manually
- Robust design for high pressure levels
- Easy integration with or without protective enclosure
- Minimal downtime thanks to mobile calibration teams at your site

Technical data for GH2 Source – stationary custody transfer metering system for hydrogen

Standard configuration. We will be happy to advise you on available options.

GH2 Source	
Medium	gaseous hydrogen
Operating pressure range	20 to 1048 bar
Q _{min} (Minimum flow rate)	0.17 kg/min
Q _t (Transitional flow rate)	0.83 kg/min
Q _{max} (Maximum flow rate)	4.17 kg/min
Cut-off threshold	0.033 kg/min
Measurement accuracy	±1.5% Q _t bis Q _{max} ±2.5% Q _{min} bis Q _t
Operating temperature for pressurized parts	-50 to +120°C
Temperature range	-40 to +55 °C
Ambient temperature range	-25 to +55 °C
Mechanical/Electrical environment	M2/E2
Power supply	24 VDC

Components and Accessories

Coriolis Flow Meter:

Type	RHM04
Housing material	Stainless steel
Wetted material	SS 316 / HP160
Process connections	Autoclave 9/16" MP (13/16"-16 UN)
Approvals	ATEX/IECEX: Zone 1 ATEX / IEC <Ex> II 2G Ex ib IIC T6...T1 Gb Certificate No.: IECEX BVS 17.0063 Note: Explosion safety regulations must be observed. Design according to PED: 2014/68/EU Art. 4(3) SEP

Coriolis Transmitter:

Type	RHE42
Housing material	Coated aluminium
Degree of protection	IP 65
Approvals	ATEX/IECEX: Zone 1 ATEX / IEC <Ex> II 2(1)G Ex db eb [ia Ga] IIC T6 Gb
Ambient temperature	-20 to +60°C
Outputs	2 analogue outputs 4–20 mA, active / passive; 2 frequency / pulse / status outputs
Inputs	2 digital signal inputs All digital I/Os: in accordance with DIN IEC 60946
Communication interfaces	Modbus RS485 Modbus TCP
Power supply	12-24 VDC +/-10%
Dimensions	Housing approx. 144 × 108 × 139 mm Weight: approx. 2.3 kg

Flow Computer C406

Housing material	Aluminium housing
Degree of protection	IP54
Approvals	ATEX/IECEX: Zone 2 ATEX <Ex> II 3G Ex ec IIC T4 Gc
Ambient temperature	-25 to +55°C
Outputs	RS232 for printer RS485 for external PLC
Operation	6 push-buttons, USB, RS485
Billing/totalising unit	Kg / Nm ³
Power supply	16-27 VDC +/-10%
Dimensions	Housing approx. 95 × 240 × 150 mm Weight: approx. 2.5 kg

Electrical Cabling

Measurement Cable:	
Length	3 m (standard), longer on request
Interface	Coriolis and transmitter

Connection Cable:	
Length	3 m (standard), longer on request
Interface	Transmitter and operator terminal
Special features	UV-resistant, chemically resistant, halogen-free, oil-resistant and low-capacitance For use between transmitter and operator terminal

Communication Cable	
Length	3 m (standard), longer on request
Interface	Operator terminal and SPS
Special features	UV-resistant, chemically resistant, halogen-free, oil-resistant and low-capacitance For use between operator terminal and SPS

Power Supply Cable:	
Length	3 m (standard), longer on request
Interface	Operator terminal and power source
Special features	Flame-retardant, UV-resistant, ozone-resistant, chemically resistant, oil-resistant, LABS-free For use between operator terminal and power source
Connector	Harting Han Ex 8D QL Set agg/gg-M20: IEC 60664-1; IEC 61984; IEC 60079-0; EN 60079-11

Certifications:

The devices are supplied with the following certificates:

- Conformity assessment
Validity: 2 years

Documentation:

- The following documentation is included with each system:
- Maintenance logbook
- Operating manual (English)
- Calibration certificate issued by Trigas FI GmbH
- Declaration of Conformity

Dimensions

1) Coriolis Flow Meter (RHM04)

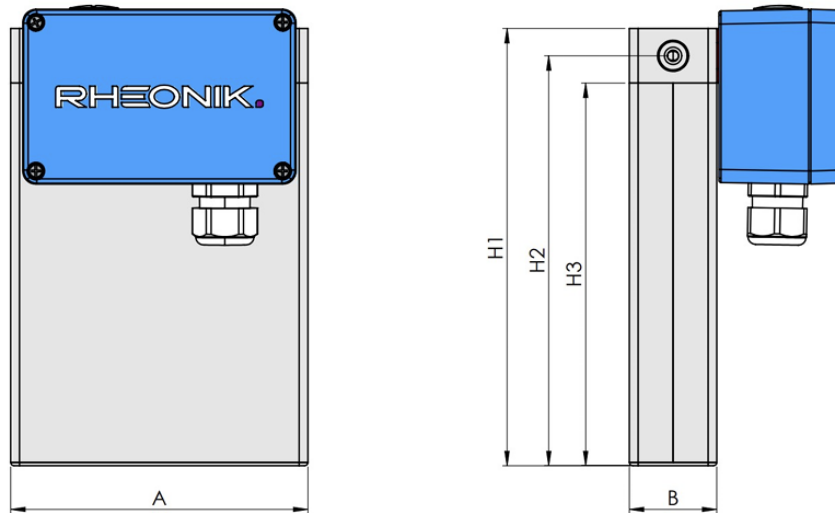

Dimensions	mm
A	136
B	40
H1	200
H2	188
H3	175

2) Coriolis Transmitter (RHE42)

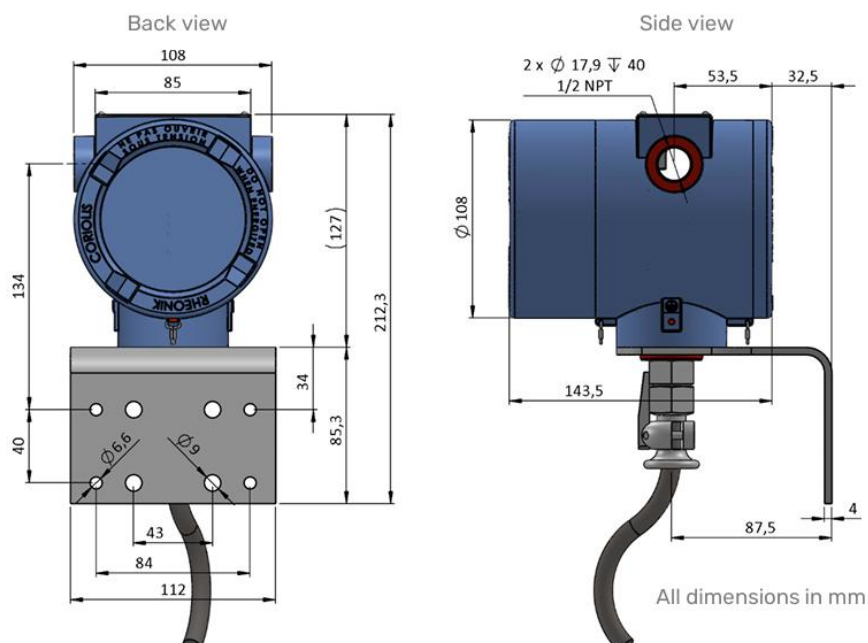

3) Flow Computer (C406)

