

# Technical Data for Alicat **MB-Series** Mass Flow Meters

## 50 slpm Full Scale through 5000 slpm Full Scale



Tel: 888-290-6060

[www.alicat.com/mb](http://www.alicat.com/mb)

Standard Specifications (Contact Alicat for available options.)

Sensor Performance	
Mass Flow Accuracy at calibration conditions <sup>1</sup>	± (0.8% of Reading + 0.2% of Full Scale)
High Accuracy Option <sup>1</sup>	± (0.4% of Reading + 0.2% of Full Scale) High Accuracy option only available for units ranged under 500 slpm.
Accuracy for Bidirectional Meters at calibration conditions after tare	± 0.2% of full scale in addition to base accuracy (above)
Repeatability (2σ)	± (0.2% of Reading + 0.02% of Full Scale)
Flow Measurement Range	0.01% - 100% of Full Scale
Temperature Sensitivity	Mass Flow Zero and Span Shift: 0.02% of Full Scale / °C
Pressure Sensitivity	Mass Flow Zero and Span Shift: ± (0.08% of Reading + 0.02% of Full Scale) / atm
Operating Temperature Range	-10 to 60°C (consult Alicat for expanded range)
Temperature Accuracy	± 0.75°C
Operating Pressure Full Scale	160 PSIA (consult Alicat for additional options)
Pressure Accuracy	Above 1 atm: ± 0.5% of Reading      Below 1 atm: ± 0.07 PSIA
Totalizer Volume Uncertainty	± 0.5% of Reading in addition to base accuracy (above)
Typical Sensor Response Time	65 - 255 ms (Adjustable)
Typical Warm-Up Time	< 1 s

<sup>1</sup> Stated accuracy is after tare under equilibrium conditions. Extreme gas behavior (especially near state boundaries) can introduce additional flow uncertainties.

Mechanical	
Minimum Operating Pressure	11.5 PSIA common mode pressure (consult Alicat for lower operating pressures) Differential pressure must exceed model pressure drop, see below for details
Maximum Operating Pressure	Damage possible above 175 PSIA common mode pressure Damage possible above 75 PSID differential pressure
Leak Integrity Option	Available to 1 x 10 <sup>-9</sup> atm cc/s helium. (consult Alicat for more information)
Ingress Protection	IP40 (consult Alicat for weatherproofing options)
Humidity Range	0 to 95% non-condensing
Wetted Materials	302/303 Stainless Steel, Viton, Polyamide, Alumina, Ceramic, Glass, Gold, Silicon Heat cured: Epoxy, RTV, Silicone

Control and Communications	
Digital I/O	Serial over Micro-USB-B
Data Update Rate	40 Hz at 19200 baud
Display Update Rate	10 Hz
Battery Life (contrast dependent)	Monochrome: 18 hrs. (14 hrs. with backlight on)      Color: 8 hrs.

Features	
STP Reference Conditions	25°C and 1 atm (Default), user configurable
NTP Reference Conditions	0°C and 1 atm (Default), user configurable
Monochrome LCD or Color TFT Display with integrated touchpad	Simultaneously displays Mass Flow, Volumetric Flow, Pressure and Temperature
<b>Gas Select™</b>	98 user selectable gases stored internally. Each gas optimized to match NIST's REFPROP 10 gas property calculations across the operating temperature and pressure ranges for highest accuracy.
<b>COMPOSER™</b>	Allows 20 user definable gas mixes Up to 5 constituent gases per mix, down to percentages of 0.01%

### Range Specific Specifications

Full Scale Flow Mass Meter	Pressure Drop at FS Flow (PSID) venting to atmosphere <sup>2</sup>	Mechanical Dimensions <sup>3</sup>	Process Connections <sup>4</sup>
50 slpm	2.0	6.0"H x 4.0"W x 1.6"D	1/4" NPT Female
100 slpm	2.5		
250 slpm	2.1	6.6"H x 4.0"W x 1.6"D	1/2" NPT Female
500 slpm	4.0	6.6"H x 4.0"W x 1.6"D	3/4" NPT Female (A 1-1/4" NPT Female optional process connection is available for 2000 slpm meters.)
1000 slpm	6.0		
2000 slpm	5.0	6.9"H x 5.2"W x 2.9"D	1-1/4" NPT Female
3000 slpm	7.1	6.9"H x 5.2"W x 2.9"D	
5000 slpm	3.4	7.9"H x 5.2"W x 3.9"D	

<sup>2</sup> Lower Pressure Drops Available, please see our **WHISPER-Series** mass flow controllers at [www.alicat.com/whisper](http://www.alicat.com/whisper).

<sup>3</sup> See drawings for metric equivalents.

<sup>4</sup> Compatible with Swagelok® tube, Parker®, face seal, push connect and compression adapter fittings. VCR and SAE connections upon request.

## Alicat Gas Select™ Preloaded Gases

PURE NON-CORROSIVE GASES		
Gas Number	Short Name	Long Name
14	C2H2	Acetylene
0	Air	Air
1	Ar	Argon
16	i-C4H10	i-Butane
13	n-C4H10	n-Butane
4	CO2	Carbon Dioxide
3	CO	Carbon Monoxide
60	D2	Deuterium
5	C2H6	Ethane
15	C2H4	Ethylene (Ethene)
7	He	Helium
6	H2	Hydrogen
17	Kr	Krypton
2	CH4	Methane
10	Ne	Neon
8	N2	Nitrogen
9	N2O	Nitrous Oxide
11	O2	Oxygen
12	C3H8	Propane
19	SF6	Sulfur Hexafluoride
18	Xe	Xenon

BREATHING GASES		
Gas Number	Short Name	Long Name
164	EAN-32	32% O2 / 68% N2
165	EAN	36% O2 / 64% N2
166	EAN-40	40% O2 / 60% N2
167	HeOx-20	20% O2 / 80% He
168	HeOx-21	21% O2 / 79% He
169	HeOx-30	30% O2 / 70% He
170	HeOx-40	40% O2 / 60% He
171	HeOx-50	50% O2 / 50% He
172	HeOx-60	60% O2 / 40% He
173	HeOx-80	80% O2 / 20% He
174	HeOx-99	99% O2 / 1% He
175	EA-40	Enriched Air-40% O2
176	EA-60	Enriched Air-60% O2
177	EA-80	Enriched Air-80% O2
178	Metabol	Metabolic Exhalant (16% O2 / 78.04% N2 / 5% CO2 / 0.96% Ar)

FUEL GASES		
Gas Number	Short Name	Long Name
185	Syn Gas-1	40% H2 + 29% CO + 20% CO2 + 11% CH4
186	Syn Gas-2	64% H2 + 28% CO + 1% CO2 + 7% CH4
187	Syn Gas-3	70% H2 + 4% CO + 25% CO2 + 1% CH4
188	Syn Gas-4	83% H2 + 14% CO + 3% CH4
189	Nat Gas-1	93% CH4 / 3% C2H6 / 1% C3H8 / 2% N2 / 1% CO2
190	Nat Gas-2	95% CH4 / 3% C2H6 / 1% N2 / 1% CO2
191	Nat Gas-3	95.2% CH4 / 2.5% C2H6 / 0.2% C3H8 / 0.1% C4H10 / 1.3% N2 / 0.7% CO2
192	Coal Gas	50% H2 / 35% CH4 / 10% CO / 5% C2H4
193	Endo	75% H2 + 25% N2
194	HHO	66.67% H2 / 33.33% O2
195	HD-5	LPG 96.1% C3H8 / 1.5% C2H6 / 0.4% C3H6 / 1.9% n-C4H10
196	HD-10	LPG 85% C3H8 / 10% C3H6 / 5% n-C4H10

BIOREACTOR GASES		
Gas Number	Short Name	Long Name
145	Bio-5M	5% CH4 / 95% CO2
146	Bio-10M	10% CH4 / 90% CO2
147	Bio-15M	15% CH4 / 85% CO2
148	Bio-20M	20% CH4 / 80% CO2
149	Bio-25M	25% CH4 / 75% CO2
150	Bio-30M	30% CH4 / 70% CO2
151	Bio-35M	35% CH4 / 65% CO2
152	Bio-40M	40% CH4 / 60% CO2
153	Bio-45M	45% CH4 / 55% CO2
154	Bio-50M	50% CH4 / 50% CO2
155	Bio-55M	55% CH4 / 45% CO2
156	Bio-60M	60% CH4 / 40% CO2
157	Bio-65M	65% CH4 / 35% CO2
158	Bio-70M	70% CH4 / 30% CO2
159	Bio-75M	75% CH4 / 25% CO2
160	Bio-80M	80% CH4 / 20% CO2
161	Bio-85M	85% CH4 / 15% CO2
162	Bio-90M	90% CH4 / 10% CO2
163	Bio-95M	95% CH4 / 5% CO2

WELDING GASES		
Gas Number	Short Name	Long Name
23	C-2	2% CO2 / 98% Ar
22	C-8	8% CO2 / 92% Ar
21	C-10	10% CO2 / 90% Ar
140	C-15	15% CO2 / 85% Ar
141	C-20	20% CO2 / 80% Ar
20	C-25	25% CO2 / 75% Ar
142	C-50	50% CO2 / 50% Ar
24	C-75	75% CO2 / 25% Ar
25	He-25	25% He / 75% Ar
143	He-50	50% He / 50% Ar
26	He-75	75% He / 25% Ar
144	He-90	90% He / 10% Ar
27	A1025	90% He / 7.5% Ar / 2.5% CO2
28	Star29	Stargon CS 90% Ar / 8% CO2 / 2% O2

STACK GASES		
Gas Number	Short Name	Long Name
200	FG-1	2.5% O2 / 10.8% CO2 / 85.7% N2 / 1% Ar
201	FG-2	2.9% O2 / 14% CO2 / 82.1% N2 / 1% Ar
202	FG-3	3.7% O2 / 15% CO2 / 80.3% N2 / 1% Ar
203	FG-4	7% O2 / 12% CO2 / 80% N2 / 1% Ar
204	FG-5	10% O2 / 9.5% CO2 / 79.5% N2 / 1% Ar
205	FG-6	13% O2 / 7% CO2 / 79% N2 / 1% Ar

CHROMATOGRAPHY GASES		
Gas Number	Short Name	Long Name
29	P-5	5% CH4 / 95% Ar
206	P-10	10% CH4 / 90% Ar

O2 CONCENTRATOR GASES		
Gas Number	Short Name	Long Name
197	OCG-89	89% O2 / 7% N2 / 4% Ar
198	OCG-93	93% O2 / 3% N2 / 4% Ar
199	OCG-95	95% O2 / 1% N2 / 4% Ar

LASER GASES		
Gas Number	Short Name	Long Name
179	LG-4.5	4.5% CO2 / 13.5% N2 / 82% He
180	LG-6	6% CO2 / 14% N2 / 80% He
181	LG-7	7% CO2 / 14% N2 / 79% He
182	LG-9	9% CO2 / 15% N2 / 76% He
183	HeNe-9	9% Ne / 91% He
184	LG-9.4	9.4% CO2 / 19.25% N2 / 71.35% He

## Additional Preloaded Gases for MS & MCS Series Units

PURE CORROSIVES*		
Gas Number	Short Name	Long Name
32	NH3	Ammonia
80	1Butene	Butylene (1-Butene)
81	cButene	Cis-Butene (cis-2-butene)
82	iButene	Iso-Butene
83	tButene	Trans-Butene
84	COS	Carbonyl Sulfide
33	Cl2	Chlorine
85	CH3OCH3	Dimethylether
34	H2S	Hydrogen Sulfide (H2S)
31	NF3	NF3 (Nitrogen Trifluoride)
30	NO	NO (Nitric Oxide)
36	C3H6	Propylene (Propylene)
86	SiH4	Silane (SiH4)
35	SO2	Sulfur Dioxide

\*Pure Corrosive gases are only available on S-Series instruments that are compatible with these gases.  
Gas numbers 33 and 35 require custom valve on controllers.

REFRIGERANTS*		
Gas Number	Short Name	Long Name
100	R-11	Trichlorofluoromethane
101	R-115	Chloropentafluoroethane
102	R-116	Hexafluoroethane
103	R-124	Chlorotetrafluoroethane
104	R-125	Pentafluoroethane
105	R-134A	Tetrafluoroethane
106	R-14	Tetrafluoromethane
107	R-142b	Chlorodifluoroethane
108	R-143a	Trifluoroethane
109	R-152a	Difluoroethane
110	R-22	Difluoromonochloromethane
111	R-23	Trifluoromethane
112	R-32	Difluoromethane
113	RC-318	Octafluorocyclobutane
114	R-404A	44% R-125 / 4% R-134A / 52% R-143A
115	R-407C	23% R-32 / 25% R-125 / 52% R-134A
116	R-410A	50% R-32 / 50% R-125
117	R-507A	50% R-125 / 50% R-143A

\*Refrigerant gases are only available on S-Series instruments that are compatible with these gases.

**MB-Series:**  
0 – 50 slpm  
0 – 100 slpm

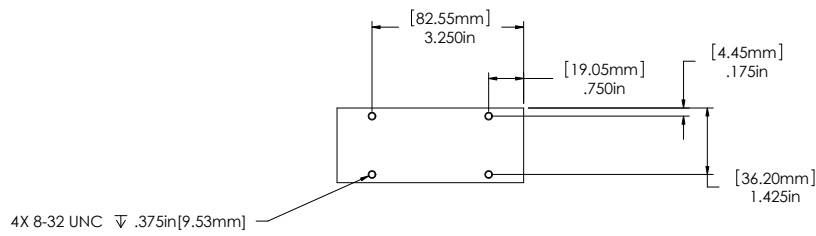
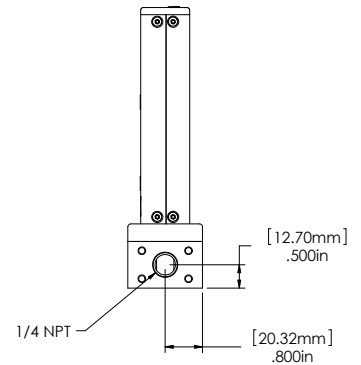
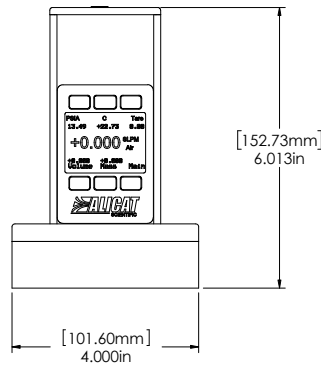
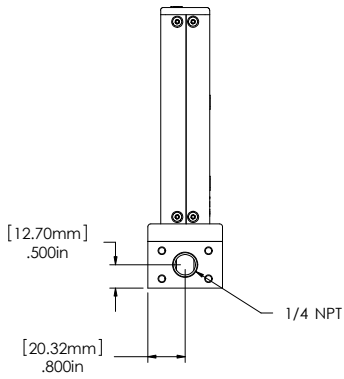
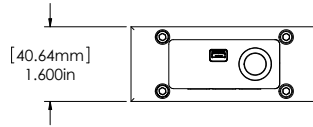

50 slpm to 100 slpm approximate shipping weight: 2.8 lb.

**MB-Series:**  
0 – 250 slpm

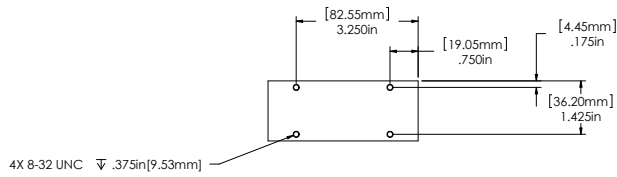
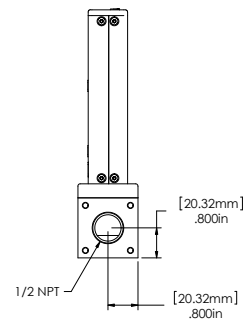
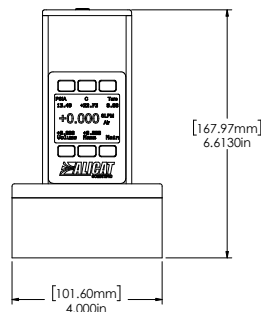
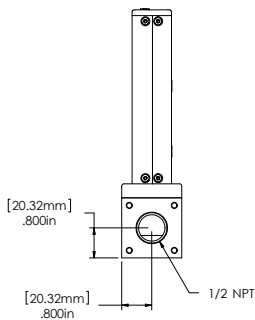
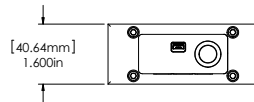

250 slpm approximate shipping weight: 3.6 lb.

**MB-Series:**  
0 – 500 slpm  
0 – 1000 slpm

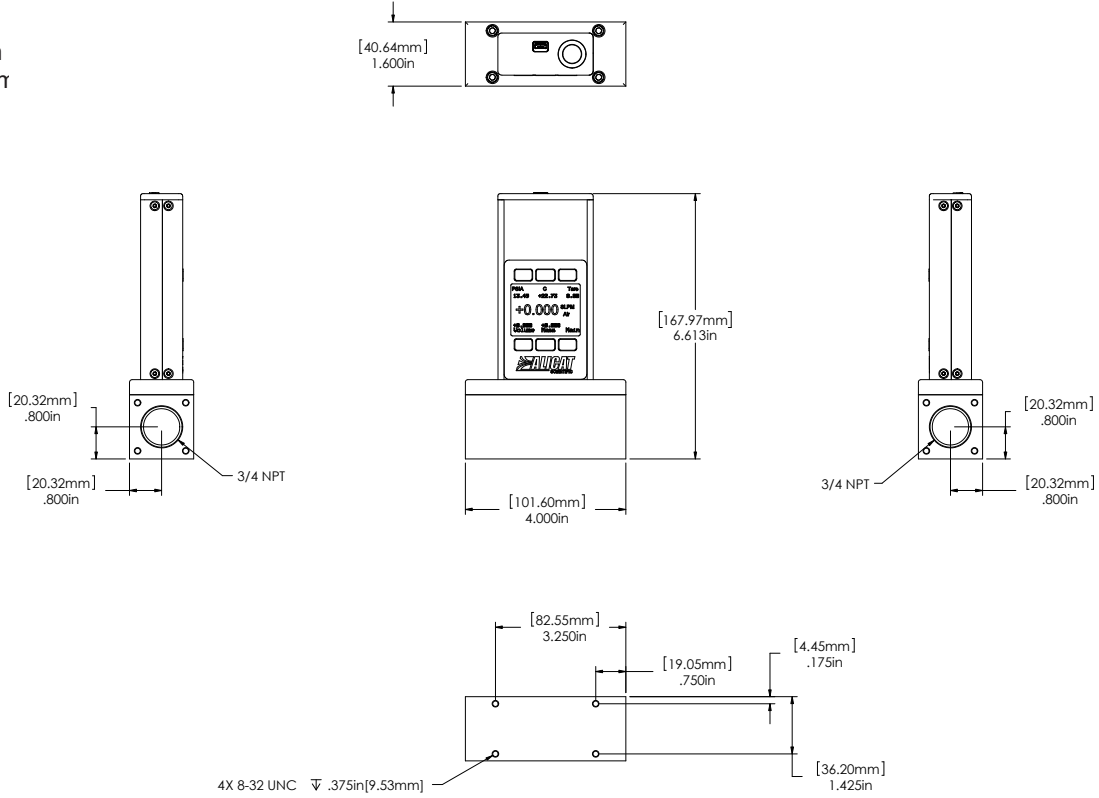

500 slpm to 1000 slpm approximate shipping weight: 3.9 lb

**MB-Series:**  
0 – 2000 slpm

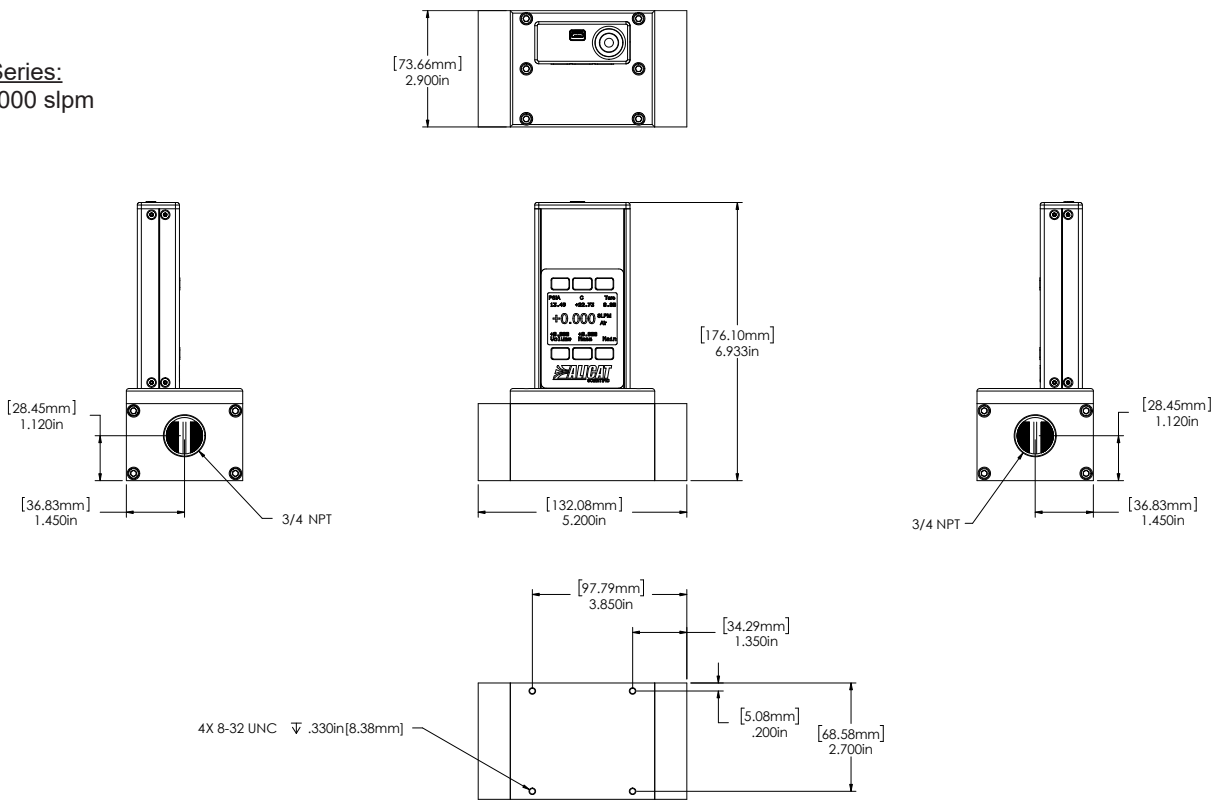

2000 slpm approximate shipping weight: 4.9 lb

**MB-Series:**  
0 – 3000 slpm

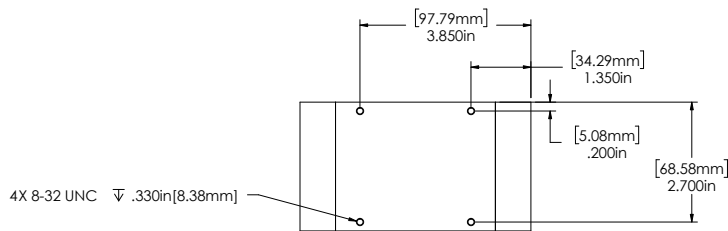
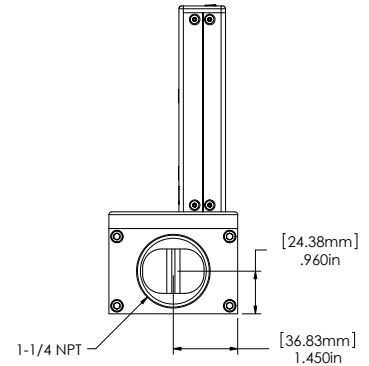
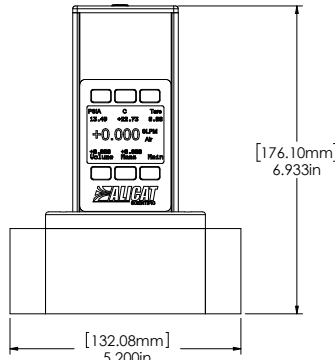
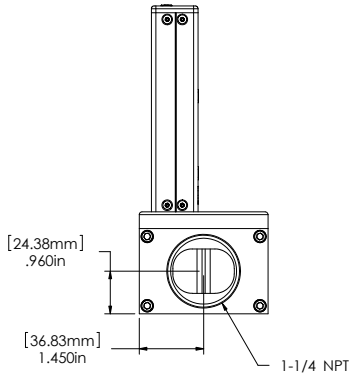
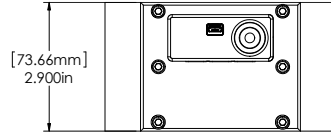

3000 slpm approximate shipping weight: 4.9 lb

**MB-Series:**  
0 – 5000 slpm

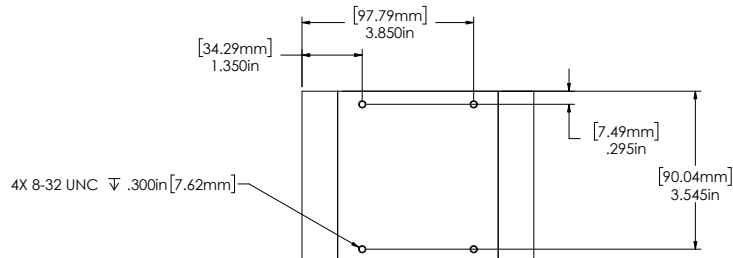
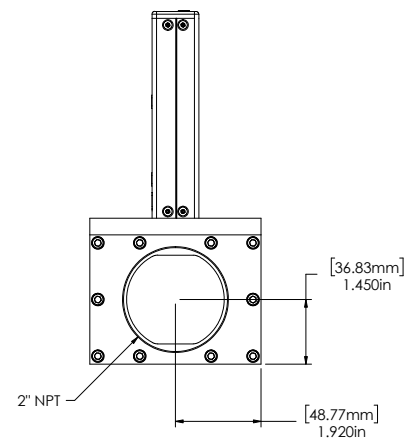
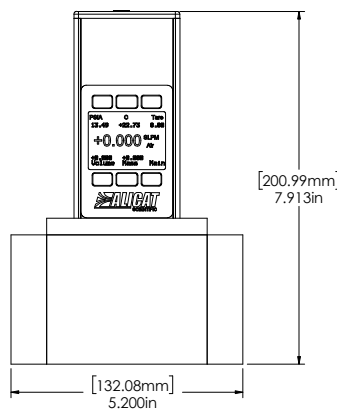
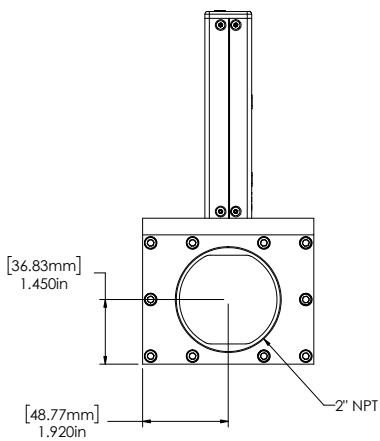
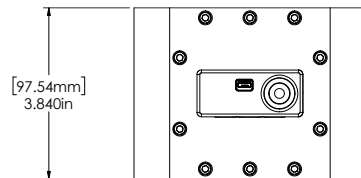

MB-5000SLPM-D-MSPEC

5000 slpm approximate shipping weight: 14.4 lb